

# Cell Type UF534042F

## Specifications

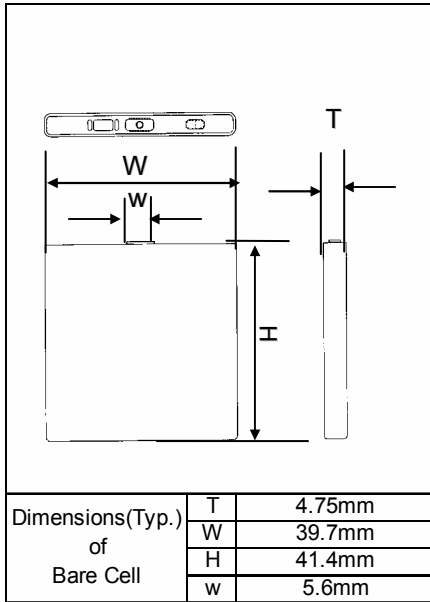

Nominal Capacity		Min.950mAh
Nominal Voltage		3.7V
Charging Method		Constant Current -Constant Voltage
Charging Voltage		4.2V
Charging Current		Std. 950mA
Charging Time		2.5hrs.
Ambient Temperature	Charge	0~+40°C
	Discharge	-20~+60°C
	Storage	-20~+50°C
Weight (Max.)		19.7g
Dimensions (Max.)	(T)	4.90mm
	(W)	39.85mm
	(H)	41.70mm
Volumetric Energy Density		431Wh/l
Gravimetric Energy Density		178Wh/kg

Discharged State after Assembling

\*The maximum thickness of the standard shipment charging condition

### Typical Characteristics

#### Discharge rate characteristics

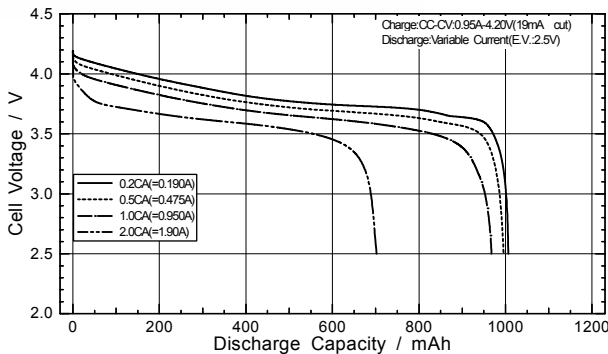

#### Discharge temperature characteristics

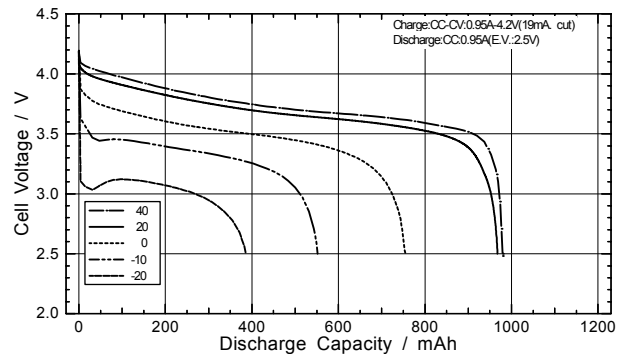

#### Charge characteristics

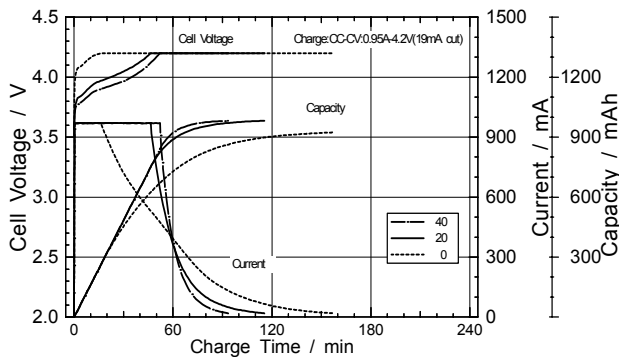

#### Cycle characteristics

